

BLCT-61-101G

The BLCT-61-101G offers an ideal meal capacity of 90-230 meals. Blodgett Combi makes it possible for you to double your capacity without using more of your valuable floor space.

Exceptional Design for Exceptional Kitchens - the Blodgett Combi is characterized by quality and simplicity. It has a unique ability to combine form and function; beauty and functionality effortlessly blends together. It enables you to reach perfection every time and with every meal.

Cook the way you want - the Blodgett Combi touchscreen control lets you choose which kind of chef you want to be. You can cook manually and easily fine-tune your settings. Use pre-programmed recipes to ensure consistent, results every time. Or use the SmartChef feature which automatically selects the optimum settings for an effortless cooking process.



CAPACITY

- ❑ Standard pan cassettes with 3.35" (85mm) spacing hold thirteen half size sheet pans or thirteen 12" x 20" x 2-1/2" deep North American hotel pans
- ❑ Optional pan cassettes with 2.56" (65mm) spacing hold sixteen half size sheet pans or sixteen 12" x 20" x 2" deep Gastronorm pans

STANDARD FEATURES

- External detachable core temperature probe with multiple measuring points. User friendly location reduces strain on the probe
- 11" tall stainless steel stand with casters
- Bright halogen lights for superior visibility
- Built in external hand shower
- Removeable cleaning chemical bottle shelf
- 5 wire shelves in top oven, 8 wire shelves in bottom oven
- Left door hinge, field reversible with purchase of kit
- Start-up inspection service by factory authorized service agent.
- One year parts and labor oven warranty*

* For all international markets, contact your local distributor.

OPTIONS & ACCESSORIES

(AT ADDITIONAL CHARGE)

- Additional core temperature probe
- Heat shield
- Extra wire oven racks
- Right hinge door
- Backflow preventer
- Extra year warranty

(AT NO ADDITIONAL CHARGE)

- Optional two piece rack system w/ 2.56" (65mm) spacing & 16 wire shelves in lieu of standard rack & shelves
- Legs in lieu of casters
- Low profile stand with casters

OVEN OPERATION

- Injection steam system - water is injected onto the heating elements, the resulting steam is distributed in the oven chamber by the fan wheel.
- Easy to use touchscreen control stores up to 500 recipes with up to 15 steps each
- Multiple cooking modes include hot air, CombiSmart, retherm, steaming, low-temperature steaming, forced steaming, proofing, preheating
- CombiOptima automatically measures and controls the humidity level in the oven
- SmartChef automatic cooking provides presets for grilling, steaming, braising, browning and breaded products. Select your desired cooking result from rare to well done, and your surface appearance from light to dark.
- Manual or automatic cooling
- Automatic humidity pulsing
- Timed steam injection or instant steam on demand at any point in the cook cycle
- Rack timing for setting individual timers for each rack
- Advanced rack timing for managing multiple recipes of the same group simultaneously on separate racks, including managing recipes to finish cooking at the same time
- Reversible 9 speed fan for optimum baking and roasting results
- Programmable vent release allows for automatic venting if desired
- USB port for data and recipe transfer
- HACCP recording and documentation
- Automated CombiWash system features very low water and detergent consumption and no contact with chemicals. No proprietary chemicals required, see owner's manual for detergent guidelines.



CONSTRUCTION

- 304 stainless steel exterior and interior
- Dual pane tempered viewing window with hinged inner glass for easy cleaning
- 2" (50mm) fixed drain in the bottom center of cavity
- Door mounted stainless steel drip tray reduces the risk of wet floors
- Separate water lines, for cooking and quench
- Automatic safety door stops in positions 110° and 180°
- Left hinge door is field convertible to the right side (with the purchase of conversion kit)
- Two step safety door latch. The first step stops the fan.

SHORT FORM SPECIFICATIONS: Provide Blodgett Combi model BLCT-61-101G gas boilerless combination-oven/steamer. The BLCT-61-101G has a pan cassette with 3.35" (85mm) spacing that holds thirteen full size sheet pans or 12" x 20" x 2-1/2" deep North American hotel pans. The optional pan cassette with 2.5" (65mm) spacing holds sixteen full size sheet pans or 12" x 20" x 2" deep Gastronorm pans.

Unit has a 304 stainless steel exterior and interior. Oven door has a dual pane tempered viewing window with hinged inner glass for easy cleaning. Includes a built in external hand shower and separate water lines. Unit shall have bright halogen lights for superior visibility and an external detachable core temperature probe. Oven has two separate water lines for cooking and quench. You may choose to cook with pressureless steam, hot air, or combination of steam and hot air.

The touchscreen control stores 500 recipes with 15 stages each, in addition to pre-programmed recipes. Multiple modes include hot air, combi, retherming, steaming, low-temperature steaming, forced steaming, proofing, cooling, and preheating. CombiOptima automatically measures and controls the humidity level in the oven. The control allows for timed steam injection or instant steam on demand at any point in the cook cycle. Rack timing provides individual timers for each rack. Advanced rack timing allows for timing multiple recipes of the same group simultaneously on separate racks of the oven. Use SmartChef automatic cooking presets for grilling, steaming, braising, browning and breaded products. HACCP quality control, USB connectivity and automatic service diagnosis are included. Programmable vent release allows for automatic venting if desired. The reversible 9 speed fan provides optimum baking and roasting results. The automated combi wash system features very low water and detergent consumption and no contact with chemicals.

Includes one-year parts and labor warranty. Provide start-up inspection service by a factory authorized service agent. Provide options and accessories as indicated.

NOTE: The company reserves the right to make substitutions of components without prior notice.

POWER SUPPLY (per section)

- 115V, 9 amp

This appliance uses a variable frequency drive, which can be known to product high frequency electrical noise. In some cases units must be hard wired. This avoids false positives on ground fault devices susceptible to errors from electrical noise. All installations must comply with local and national codes.

GAS SUPPLY (per section)

3/4" NPT

Inlet Pressure

- Natural - 3.2-8.0" W.C. static to unit
- Propane - 5.2-14" W.C. static to unit

Maximum Pressure

- 50,000 BTU/hr (top oven, 61G)
- 80,000 BTU/hr (bottom oven, 101G)

WATER SUPPLY

Good quality water feed is the responsibility of the owner. Water quality must be within the following general guidelines.

TDS: 40-125 ppm

pH: 7.0-8.5

Hardness: 35-180 ppm

Silica: <13 ppm

Chloramine: <0.2 ppm

Chlorine: <0.2 ppm

Chlorides: <25 ppm

The best defense against poor water quality is a water treatment system designed to meet your water quality conditions. Blodgett offers optional water treatment systems.

Pressure (per section)

- 40 (min)-50 (max) PSI

Connections (per section)

- 2" drain connection - max. drain temperature 140°F (60°C)
- 3/4" garden hose cold water

DRAIN

The drain piping must consist of temperature resistant material, greater than 160°F, and be of adequate diameter not to cause flow restriction. Improper materials may deform and cause restrictions, thus affecting performance.

Appliance is to be installed with backflow protection in accordance with federal, state or local codes.



DIMENSIONS ARE IN INCHES (MM)

LEGEND

- F FILTERED WATER
- U UNFILTERED WATER
- D DRAIN
- E ELECTRICAL
- G GAS
- V DRAIN VENT
- B BOILER BURNER EXHAUST
- A HOT AIR BURNER EXHAUST
- I INTAKE

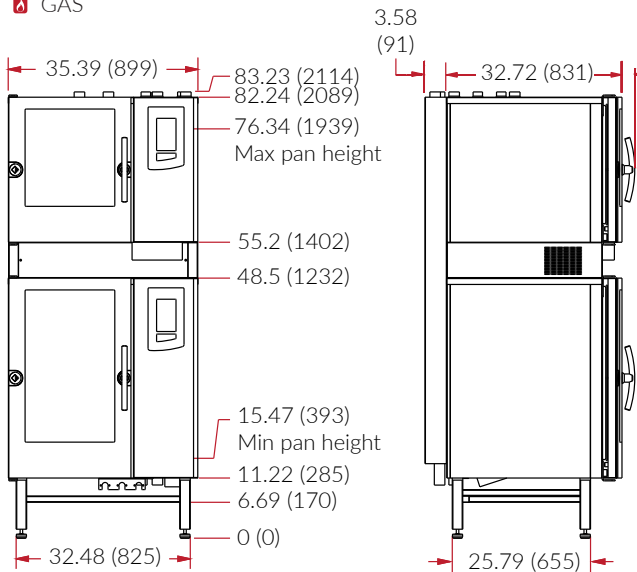

FRONT VIEW

SIDE VIEW

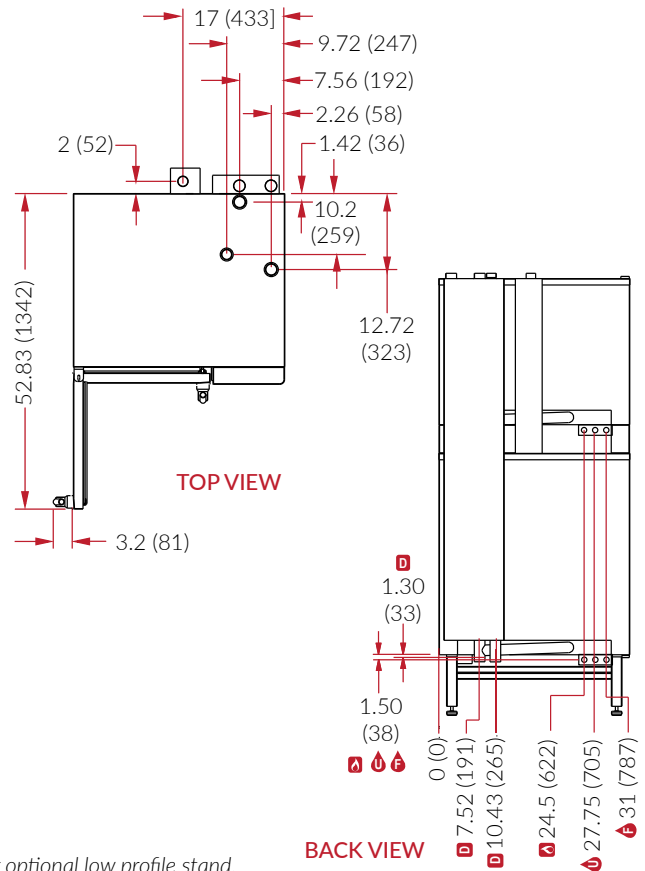

TOP VIEW

BACK VIEW

Shown on standard stand. Subtract 3.59" from all height dimensions for optional low profile stand.

SHIPPING

	WEIGHT
61G	505 lbs (229 kg)
101G	599 lbs (272 kg)
	CRATE SIZE
Each oven	40" H x 47" W x 38" D (1016 x 1194 x 965 mm)

DIMENSIONS & CLEARANCES

FLOOR SPACE	
35.39" x 32.72" (899 x 831mm)	
UNIT HEIGHT	
On standard stand	83.23" (2114mm)
On low profile stand	79.64" (2023mm)
MINIMUM ENTRY CLEARANCES (per section)	
Uncrated	29.06" (738mm)
Crated	38" (965mm)
OVEN INSTALLATION CLEARANCE REQUIREMENTS	

Kitchen Environment	Low temp.	High temp.*
Left Side & Back	2" (50mm)	2" (50mm)
Right (control) Side	2.8" (70mm)	16" (400mm)

* includes heat sources (fryers, hot plates, etc) placed on the control side of the combi

For servicing, Blodgett recommends maintaining at least 16" (400 mm) between the control side and walls or non moveable equipment.

